



# FIRE SPRINKLER SYSTEM FREEZE PROTECTION – XL-TRACE SYSTEM

This step-by-step design guide provides the tools necessary to design a nVent RAYCHEM XL-Trace fire sprinkler freeze protection system. For other applications or for design assistance, contact your nVent representative or call (800) 545-6258. Also, visit our web site at nVent.com.

## CONTENTS

<b>INTRODUCTION .....</b>	<b>1</b>
How to Use this Guide.....	2
Safety Guidelines.....	2
Warranty.....	2
<b>SYSTEM OVERVIEW .....</b>	<b>3</b>
Approvals .....	3
Self-Regulating Heating Cable Construction.....	4
<b>FIRE SUPPRESSION SYSTEM FREEZE PROTECTION APPLICATIONS ...</b>	<b>5</b>
Typical Pipe Freeze Protection System .....	5
Fire Supply Lines .....	6
Sprinkler Standpipes .....	8
Branch Lines with Sprinklers .....	9
Freezer Application .....	10
<b>FIRE SUPPRESSION SYSTEM FREEZE PROTECTION DESIGN .....</b>	<b>11</b>
Design Step by Step.....	11
Step 1 Determine design conditions and pipe heat loss.....	12
Step 2 Select the heating cable.....	17
Step 3 Determine the heating cable length.....	19
Step 4 Determine the electrical parameters.....	21
Step 5 Select the connection kits and accessories .....	24
Step 6 Select the control system .....	29
Step 7 Complete the Bill of Materials.....	30
<b>INSTALLATION AND MAINTENANCE .....</b>	<b>31</b>
<b>XL-TRACE SYSTEM FIRE SPRINKLER SYSTEM FREEZE PROTECTION DESIGN WORKSHEET .....</b>	<b>32</b>

## INTRODUCTION

This design guide presents nVent recommendations for designing an XL-Trace pipe freeze protection system for fire sprinkler piping. It provides design and performance data, control options, electrical sizing information, and application configuration suggestions. This guide does not give information on how to design your fire protection system.

This guide does **not** cover applications in which any of the following conditions exist:

- Hazardous locations, as defined in national electrical codes
- Supply voltage other than 120 V or 208–277 V

If your application conditions are different, or if you have any questions, contact your nVent representative or call (800) 545-6258.

## How to Use this Guide

This design guide takes you step by step through designing a freeze protection system for fire suppression piping. Following these recommendations will result in a reliable, energy-efficient system.

### OTHER REQUIRED DOCUMENTS

This guide is not intended to provide comprehensive installation instructions. For complete system installation instructions, please refer to the following additional required documents:

- XL-Trace System Installation and Operation Manual (H58033)
- Additional installation instructions are included with the connection kits, controllers, and accessories

If you do not have the above documents, you can obtain them from the nVent web site at [nVent.com](http://nVent.com).

For products and applications not covered by this design guide, please contact your nVent representative or call (800) 545-6258.

## Safety Guidelines

As with any electrical equipment, the safety and reliability of any system depends on the quality of the products selected and the manner in which they are installed and maintained. Incorrect design, handling, installation, or maintenance of any of the system connection kits could damage the system and may result in inadequate performance, overheating, electric shock, or fire. To minimize these risks and to ensure that the system performs reliably, read and carefully follow the information, warnings, and instructions in this guide.



This symbol identifies important instructions or information.



This symbol identifies particularly important safety warnings that must be followed.



**WARNING:** To minimize the danger of fire from sustained electrical arcing if the heating cable is damaged or improperly installed, and to comply with the requirements of nVent, agency certifications, and national electrical codes, ground-fault equipment protection must be used on each heating cable branch circuit. Arcing may not be stopped by conventional circuit protection.

## Warranty



nVent standard limited warranty applies to all products.

An extension of the limited warranty period to ten (10) years from the date of installation is available if a properly completed online warranty form is submitted within thirty (30) days from the date of installation. You can access the complete warranty on our web site at [nVent.com](http://nVent.com).

## SYSTEM OVERVIEW

---

The XL-Trace system is designed to freeze protect aboveground and buried supply pipes, fire standpipes, branch lines and branch lines containing sprinklers when run in areas subject to freezing.

nVent offers the option of three self-regulating heating cables with the XL-Trace system; 5XL, 8XL, and 12XL for applications using 120 V and 208–277 V power supplies. The XL-Trace system is based on self-regulating heating cable technology whereby the heating cable's output is reduced automatically as the pipe warms; eliminating the possibility of sprinkler system overheating.

An XL-Trace system includes the heating cable, power connection, splice, tee connections, controls, power distribution panels, accessories, and the tools necessary for a complete installation.

### Approvals

NFPA 13 (Standard for the Installation of Sprinkler Systems) allows Listed electrical heat tracing to freeze protect fire suppression systems including supply lines, standpipes and branch lines containing sprinklers. XL-Trace is c-CSA-us Certified for use on fire suppression systems under CSA C22.2 No. 130-03 for Canada and IEEE 515.1-2005 for the US. The system covered in this manual includes supply lines, stand pipes, branch lines and sprinkler heads.

## Self-Regulating Heating Cable Construction

XL-Trace self-regulating heating cables are comprised of two parallel nickel-plated bus wires in a cross-linked polymer core, a tinned copper braid, and a fluoropolymer or polyolefin outer jacket. These cables are cut to length, simplifying the application design and installation.

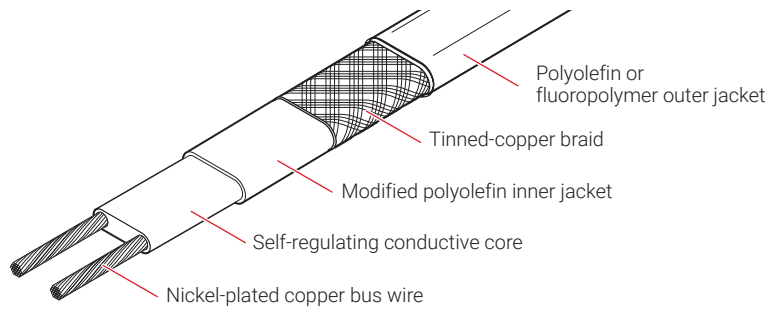

**Fig. 1 XL-Trace heating cable construction**

With self-regulating technology, the number of electrical paths between bus wires changes in response to temperature fluctuations. As the temperature surrounding the heater decreases, the conductive core contracts microscopically. This contraction decreases electrical resistance and creates numerous electrical paths between the bus wires. Current flows across these paths to warm the core.

As the temperature rises, the core expands microscopically. This expansion increases electrical resistance and the number of electrical paths decreases. The heating cable automatically reduces its output.

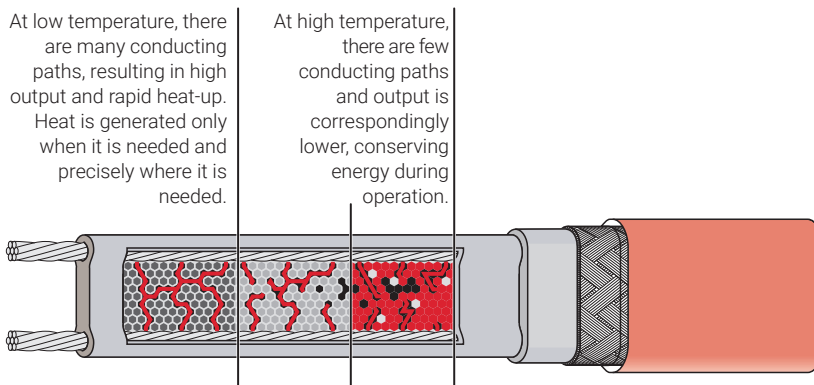

At low temperature, there are many conducting paths, resulting in high output and rapid heat-up. Heat is generated only when it is needed and precisely where it is needed.

At high temperature, there are few conducting paths and output is correspondingly lower, conserving energy during operation.

At moderate temperature, there are fewer conducting paths because the heating cable efficiently adjusts by decreasing output, eliminating any possibility of overheating.

The following graphs illustrate the response of self-regulating heating cables to changes in temperature. As the temperature rises, electrical resistance increases, and our heaters reduce their power output.

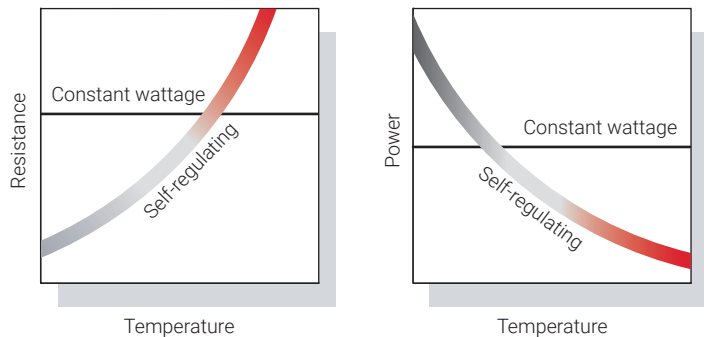

**Fig. 2 Self-regulating heating cable technology**

## FIRE SUPPRESSION SYSTEM FREEZE PROTECTION APPLICATIONS

A freeze protection system is designed to maintain water temperature at a minimum of 40°F (4°C) to prevent fire suppression piping from freezing.

### Typical Pipe Freeze Protection System

A typical freeze protection system includes the XL-Trace self-regulating heating cables, connection kits, temperature control, and power distribution.

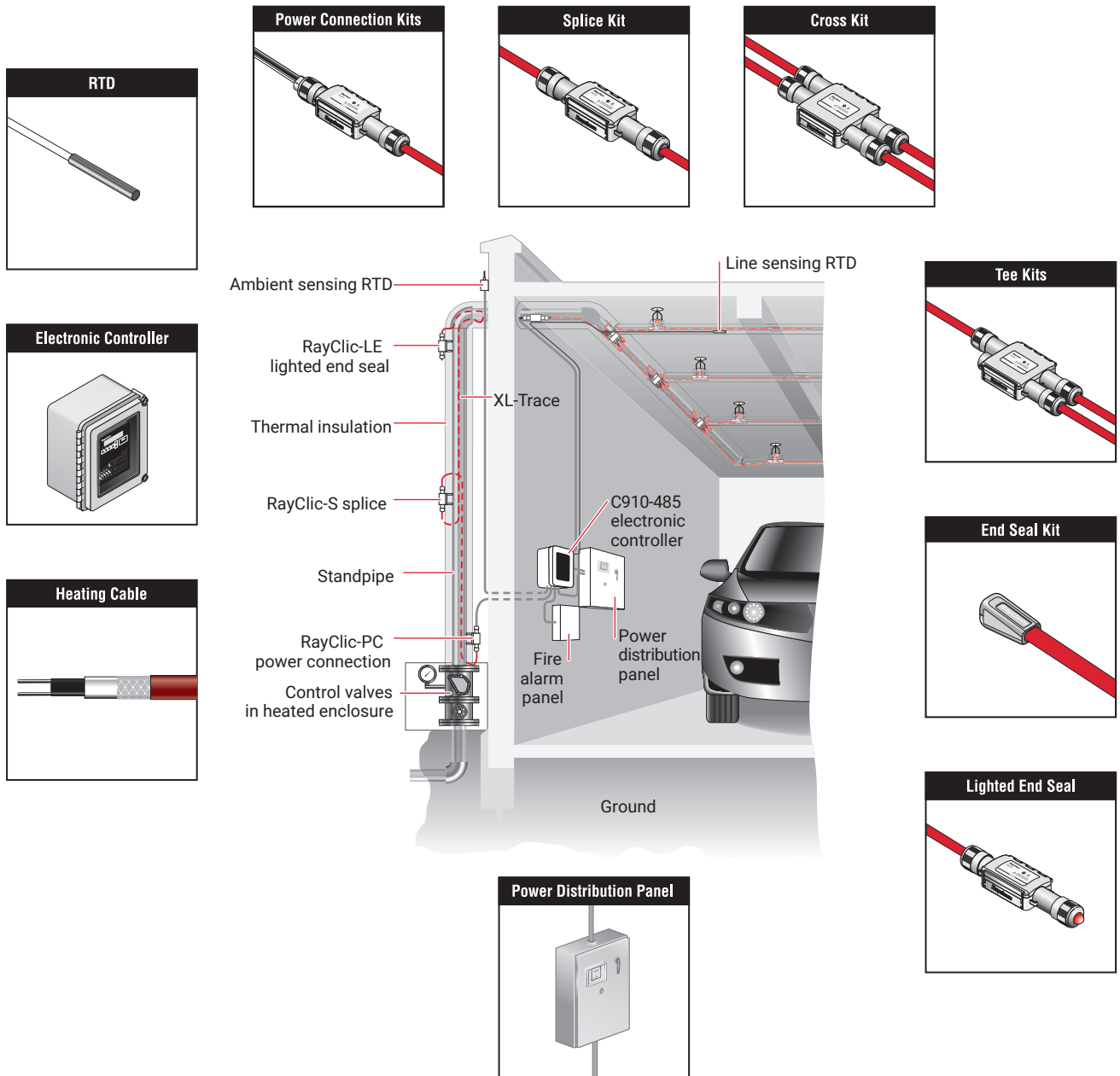
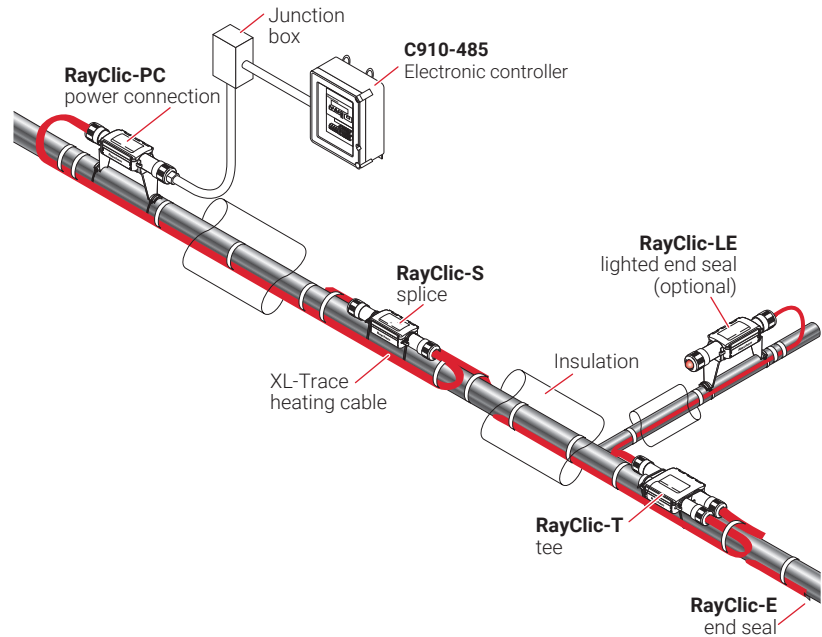

Fig. 3 Typical XL-Trace pipe freeze protection system

## Fire Supply Lines

XL-Trace is designed to maintain fire supply lines at 40°F (4°C) in areas subject to freezing.

### ABOVEGROUND SUPPLY PIPING



**Fig. 4 Typical aboveground supply piping system**

#### Application Requirements

The system complies with nVent requirements for aboveground general water piping when:

- The heating cable is permanently secured to insulated metal pipes with GT-66 glass tape or to plastic pipes using AT-180 aluminum tape.
- nVent RAYCHEM C910-485 or ACS-30 controllers with integrated ground-fault protection and alarm contacts are used and are connected to a fire control panel.
- The heating cable is installed per manufacturer's instructions with approved nVent RAYCHEM connection kits. See Table 11 on page 25 and the XL-Trace System Installation and Operation Manual (H58033).

#### Approvals

c-CSA-us Certified for nonhazardous locations.



5XL1-CR, -CT    8XL1-CR, -CT    12XL2-CR, -CT  
5XL2-CR, -CT    8XL2-CR, -CT

## BURIED PIPING

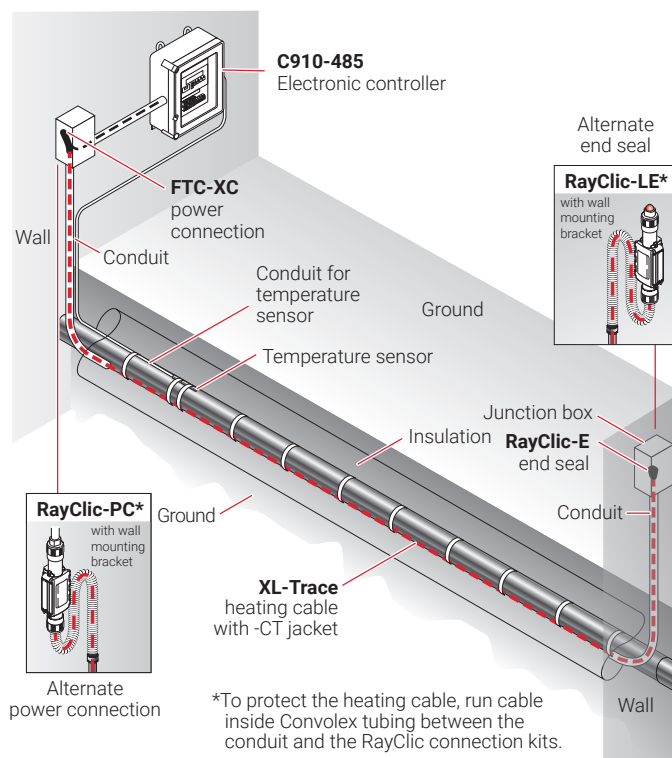

**Fig. 5 Typical buried piping system**

### Application Requirements

The system complies with nVent requirements for use on buried insulated metal or plastic pipe when:

- The heating cable is permanently secured to insulated metal pipes with GT-66 glass tape or to plastic pipes using AT-180 aluminum tape.
- The pipeline is buried at least 2-feet deep.
- The heating cable has a fluoropolymer outer jacket (-CT).
- All heating cable connections (power, splice, tee, and end termination) are made aboveground. No buried or in-conduit splices or tees are allowed.
- The power connection and end seal are made in UL Listed and CSA Certified junction boxes, or nVent RAYCHEM RayClic connection kits, above grade.
- The heating cable is protected from the pipe to the power connection box in UL Listed and CSA Certified water-sealed conduit (minimum 3/4-inch diameter) suitable for the location.
- C910-485 or ACS-30 controllers with integrated ground-fault protection and alarm contacts are used and are connected to a fire control panel.
- Closed-cell, waterproof thermal insulation with fire-retardant, waterproof covering approved for direct burial is used.
- The heating cable is installed per manufacturer's instructions with approved nVent connection kits. See Table 13 on page 27 and the XL-Trace System Installation and Operation Manual (H58033).

### Approvals

c-CSA-us Certified for nonhazardous locations.



5XL1-CT	8XL1-CT	12XL2-CT
5XL2-CT	8XL2-CT	

## Sprinkler Standpipes

XL-Trace is designed to maintain fire suppression system standpipes at 40°F (4°C) in areas subject to freezing.

### FOR ABOVEGROUND STANDPIPES

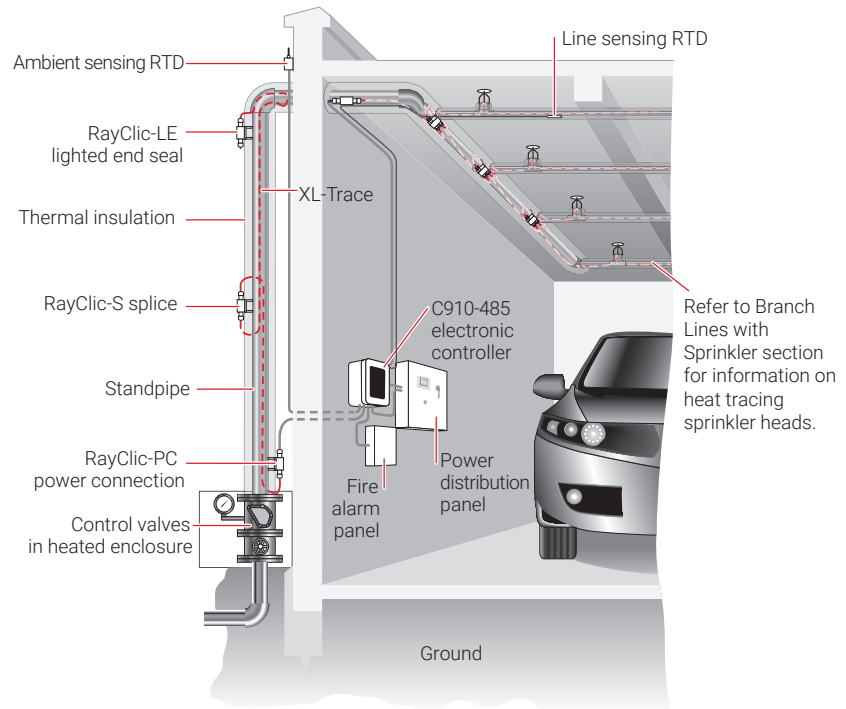

**Fig. 6 Standard sprinkler standpipe heating system layout**

### Application Requirements

The system complies with nVent requirements for freeze protection of sprinkler system piping when:

- The heating cable is permanently secured to insulated metal pipes with GT-66 glass tape or to plastic pipes using AT-180 aluminum tape.
- Schedule 5, 10, 20, or 40 steel sprinkler standpipe up to and including 20 inches in diameter is used.
- UL Listed fiberglass or closed cell flame-retardant insulation with weatherproof cladding is used.
- C910-485 or ACS-30 controllers with integrated ground-fault protection and alarm contacts are used and are connected to a fire control panel.
- The heating cable is installed per manufacturer's instructions with approved nVent connection kits. See Table 11 on page 25 and the XL-Trace System Installation and Operation Manual (H58033).

### Approvals

c-CSA-us Certified for nonhazardous locations.



5XL1-CR, -CT   8XL1-CR, -CT   12XL2-CR, -CT  
5XL2-CR, -CT   8XL2-CR, -CT



## Branch Lines with Sprinklers

XL-Trace is designed to maintain branch lines containing sprinklers at 40°F (4°C) in areas subject to freezing.

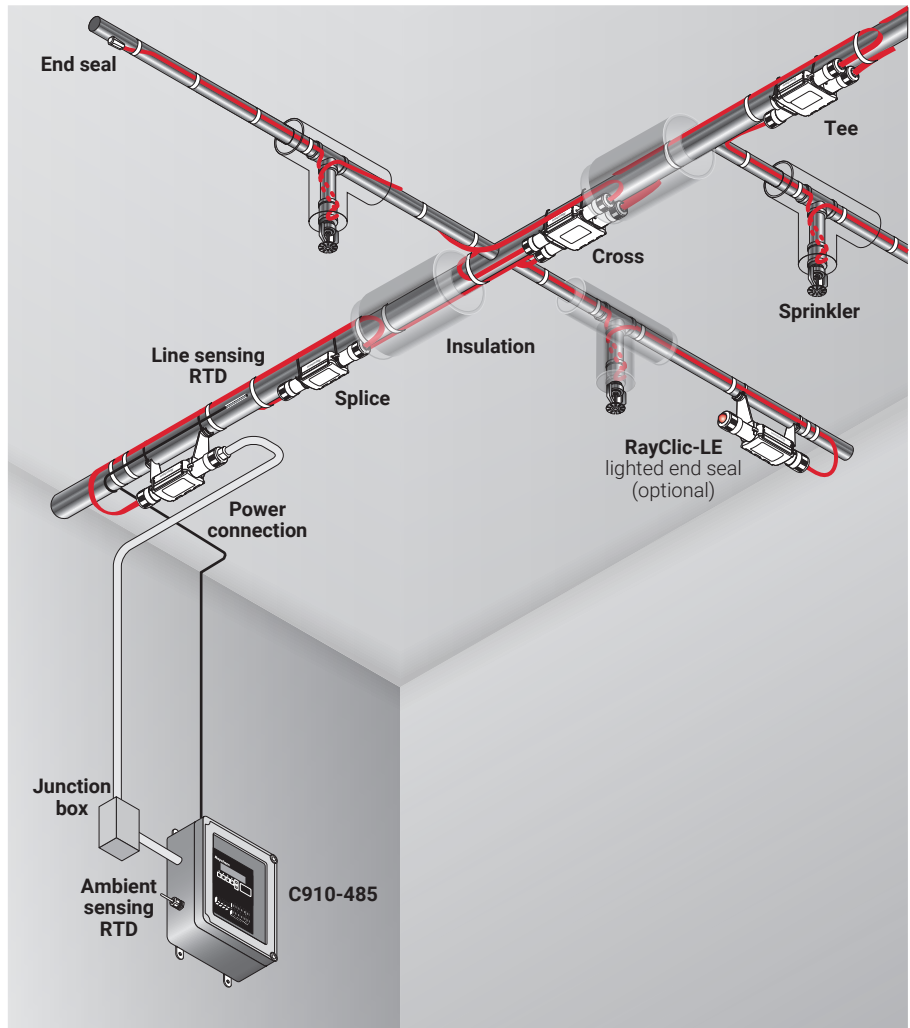

**Fig. 7 Typical fire suppression system for branch lines with sprinklers**

### Application Requirements

The system complies with nVent requirements for fire suppression branch lines with sprinklers when:

- The heating cable is permanently secured to metal pipes with GT-66 glass tape, or to plastic pipes using AT-180 aluminum tape.
- C910-485 or ACS-30 controllers with integrated ground-fault protection with alarm contacts are used and are connected to a fire control panel.
- The sprinkler design accounts for the sprinkler shadow created by the outer diameter of the thermal pipe insulation.
- Closed-cell, waterproof thermal insulation with fire-retardant, waterproof covering is used.
- The heating cable is installed per manufacturer's instructions with approved nVent connection kits. See Table 13 on page 27 and the XL-Trace System Installation and Operation Manual (H58033).
- Additional heating cable is installed to compensate for sprinkler heads, sprigs, valves and pipe supports as detailed in the Table 6 on page 20 of this document and the XL-Trace System Installation and Operation Manual (H58033).

## Approvals

c-CSA-us Certified for use in U.S. and Canada in nonhazardous locations.



5XL1-CR, -CT 8XL1-CR, -CT  
5XL2-CR, -CT 8XL2-CR, -CT

## Freezer Application

XL-Trace is designed to keep condensate in dry sprinklers from freezing and may be installed in freezers located in areas subject to freezing.

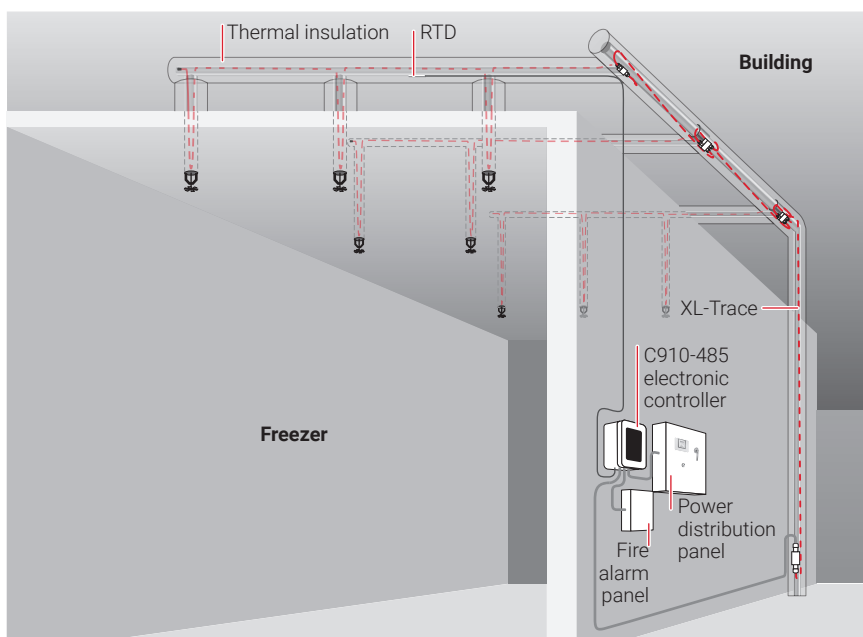

**Fig. 8 Typical fire suppression system for freezer applications**

## Application Requirements

The system complies with nVent requirements for fire suppression systems for freezer applications when:

- The system is for freezer and freezer within a freezer applications.
- The heating cable is permanently secured to metal pipes with GT-66 glass tape, or to plastic pipes using AT-180 aluminum tape.
- C910-485 or ACS-30 controllers with integrated ground-fault protection and alarm contacts are used and are connected to a fire control panel.
- Closed-cell, waterproof thermal insulation with fire-retardant, waterproof covering is used for pipes and sprigs in areas subject to freezing.
- The sprinkler design accounts for sprinkler shadow created by the outer diameter of the thermal pipe insulation.
- The heating cable is installed per manufacturer's instructions with approved nVent connection kits. See Table 13 on page 27 and the XL-Trace System Installation and Operation Manual (H58033).
- Additional heating cable is installed to compensate for sprinkler heads, sprigs, valves and pipe supports as detailed in the Table 6 on page 20 of this document and the XL-Trace System Installation and Operation Manual (H58033).

## Approvals

c-CSA-us Certified for use in U.S. and Canada in nonhazardous locations.



5XL1-CR, -CT 8XL1-CR, -CT  
5XL2-CR, -CT 8XL2-CR, -CT

## FIRE SUPPRESSION SYSTEM FREEZE PROTECTION DESIGN

---



This section details the design steps necessary to design your application. The examples provided in each step are intended to incrementally illustrate the project parameter output for two sample designs from start to finish. As you go through each step, use the "XL-Trace System Fire Sprinkler System Freeze Protection Design Worksheet," page 32, to document your project parameters, so that by the end of this section you will have the information you need for your Bill of Materials.

TraceCalc Pro for Buildings is an online design tool available to help you create simple or complex heat-tracing designs for pipe freeze protection or flow maintenance applications. It is available at [nVent.com](http://nVent.com).

### Design Step by Step

**Your system design requires the following essential steps.**

- 1** Determine design conditions and pipe heat loss
- 2** Select the heating cable
- 3** Determine the heating cable length
- 4** Determine the electrical parameters
- 5** Select the connection kits and accessories
- 6** Select the control system
- 7** Complete the Bill of Materials

Pipe Freeze Protection and Flow Maintenance
1. Determine design conditions and pipe heat loss
2. Select the heating cable
3. Determine the heating cable length
4. Determine the electrical parameters
5. Select the connection kits and accessories
6. Select the control system
7. Complete the Bill of Materials

## Step 1 Determine design conditions and pipe heat loss

Collect the following information to determine your design conditions:

- Location
  - Indoors
  - Outdoors
  - Aboveground
  - Buried
- Maintain temperature ( $T_M$ )
- Minimum ambient temperature ( $T_A$ )
- Pipe diameter and material
- Pipe length
- Thermal insulation type and thickness
- Supply voltage

### Example: Fire Standpipe

Location	Aboveground, outdoors
Maintain temperature ( $T_M$ )	40°F (4°C)
Minimum ambient temperature ( $T_A$ )	-20°F (-29°C)
Pipe diameter and material	10-inch metal
Pipe length	50 ft (16.4 m)
Thermal insulation type and thickness	1 1/2-inch fiberglass
Supply voltage	208 V

### Branch Line with Sprinkler

Location	Indoors
Maintain temperature ( $T_M$ )	40°F (4°C)
Minimum ambient temperature ( $T_A$ )	0°F (-18°C)
Pipe diameter and material	1-inch metal
Pipe length	200 ft (61 m)
Thermal insulation type and thickness	1/2-inch closed-cell foamed elastomer
Supply voltage	208 V

## PIPE HEAT LOSS CALCULATIONS

To select the proper heating cable you must first determine the pipe heat loss. To do this you must first calculate the temperature differential ( $\Delta T$ ) between the pipe maintain temperature and the minimum ambient temperature.

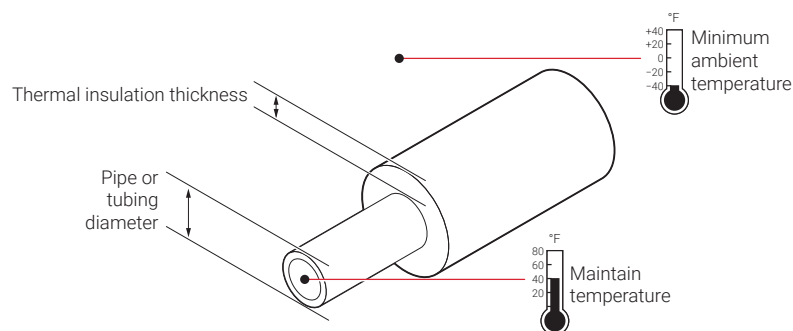

**Fig. 9 Pipe heat loss**

### Calculate temperature differential $\Delta T$

To calculate the temperature differential ( $\Delta T$ ), use the formula below:

$$\Delta T = T_M - T_A$$

#### Example: Fire Standpipe

$T_M$	40°F (4°C)
$T_A$	-20°F (-29°C)
	$\Delta T = 40^\circ\text{F} - (-20^\circ\text{F}) = 60^\circ\text{F}$
	$\Delta T = 4^\circ\text{C} - (-29^\circ\text{C}) = 33^\circ\text{C}$

#### Example: Branch Line with Sprinkler

$T_M$	40°F (4°C)
$T_A$	0°F (-18°C)
	$\Delta T = 40^\circ\text{F} - (0^\circ\text{F}) = 40^\circ\text{F}$
	$\Delta T = 4^\circ\text{C} - (-18^\circ\text{C}) = 22^\circ\text{C}$

### Determine the pipe heat loss

Match the pipe size, insulation thickness, and temperature differential ( $\Delta T$ ) from Table 1 on page 15 to determine the base heat loss of the pipe ( $Q_B$ ).

#### Example: Fire Standpipe

Pipe diameter	10 inch
Insulation thickness	1 1/2 inch
$\Delta T$	60°F (33°C)

Heat loss ( $Q_B$ ) for 60°F must be calculated through interpolation between  $\Delta T$  at 50°F and  $\Delta T$  at 100°F from Table 1. For difference between the  $\Delta T$  of 50°F and the  $\Delta T$  of 100°F:

$Q_{B-50}$	8.1 W/ft (from Table 1)
$Q_{B-100}$	16.8 W/ft (from Table 1)
$\Delta T$ interpolation	$\Delta T$ 60°F is 20% of the distance between $\Delta T$ 50°F and $\Delta T$ 100°F
$Q_{B-60}$	$Q_{B-50} + [0.20 \times (Q_{B-100} - Q_{B-50})] = 8.1 + [0.20 \times (16.8 - 8.1)] = 9.8 \text{ W/ft}$
Pipe heat loss ( $Q_B$ )	<b>9.8 W/ft @ <math>T_M</math> 40°F</b> <b>(32.1 W/m @ <math>T_M</math> 4°C)</b>

### Example: Branch Line with Sprinkler

Pipe diameter	1 inch
Insulation thickness	1/2 inch
$\Delta T$	40°F (22°C)
$Q_B$ for 40°F must be calculated through interpolation between $\Delta T$ at 20°F and $\Delta T$ at 50°F from Table 1. For difference between the $\Delta T$ of 20°F and the $\Delta T$ of 50°F:	
$Q_{B-20}$	1.4 W/ft (from Table 1)
$Q_{B-50}$	3.5 W/ft (from Table 1)
$\Delta T$ interpolation	$\Delta T$ 40°F is 67% of the distance between $\Delta T$ 20°F and $\Delta T$ 50°F
$Q_{B-40}$	$Q_{B-50} + [0.67 \times (Q_{B-50} - Q_{B-20})] = 1.4 + [0.67 \times (3.5 - 1.4)] = 2.8 \text{ W/ft}$
Pipe heat loss $Q_B$	<b>2.8 W/ft @ <math>T_M</math> 40°F</b> <b>(9.2 W/m @ <math>T_M</math> 4°C)</b>

### Compensate for insulation type and pipe location

The base heat loss is calculated for a pipe insulated with thermal insulation with a k-factor ranging from 0.2 to 0.3 BTU/hr-°F-ft<sup>2</sup>/in (fiberglass or foamed elastomer) in an outdoor, or buried application. To get the heat loss for pipes insulated with alternate types of thermal insulation and for pipes installed indoors, multiply the base heat loss of the pipe ( $Q_B$ ) from Step 3 by the insulation multiple from Table 3 on page 16 and the indoor multiple from Table 2 on page 16 to get the corrected heat loss:

$$Q_{\text{CORRECTED}} = Q_B \times \text{Insulation multiple} \times \text{Indoor multiple}$$

### Example: Fire Standpipe

Location	Aboveground, outdoors
Thermal insulation thickness and type	1 1/2-inch fiberglass
Pipe heat loss $Q_B$	9.8 W/ft @ $T_M$ 40°F (32.1 W/m @ $T_M$ 4°C)
$Q_{\text{CORRECTED}}$	$9.8 \text{ W/ft} \times 1.00 \times 1.00 = \mathbf{9.8 \text{ W/ft @ } T_M \text{ 40°F (32.1 W/m @ } T_M \text{ 4°C)}$

### Example: Branch Line with Sprinkler

Location	Aboveground, indoors
Thermal insulation type and thickness	1/2-inch closed cell foamed elastomer
Pipe heat loss $Q_B =$	2.8 W/ft @ $T_M$ 40°F (9.2 W/m @ $T_M$ 4°C)
$Q_{\text{CORRECTED}} =$	$2.8 \text{ W/ft} \times 1.0 \times 0.79 = \mathbf{2.20 \text{ W/ft @ } T_M \text{ 410°F (7.3 W/m @ } T_M \text{ 4°C)}$

**TABLE 1 PIPE HEAT LOSS (Q<sub>B</sub>) FOR OUTDOOR OR BURIED PIPE (W/FT) FOR 1/2 TO 3-1/2 INCHES**

Insulation thickness (in)	(ΔT)		Pipe diameter (IPS) in inches								
	°F	°C	1/2	3/4	1	1-1/4	1-1/2	2	2-1/2	3	3-1/2
0.5	20	11	1.0	1.2	1.4	1.6	1.8	2.2	2.5	3.0	3.4
	50	28	2.5	2.9	3.5	4.1	4.6	5.5	6.5	7.7	8.6
	100	56	5.2	6.1	7.2	8.6	9.6	11.5	13.5	16.0	18.0
	150	83	8.1	9.5	11.2	13.4	14.9	17.9	21.1	25.0	28.1
1.0	20	11	0.6	0.7	0.8	1.0	1.1	1.3	1.5	1.7	1.9
	50	28	1.6	1.9	2.2	2.5	2.8	3.2	3.8	4.4	4.9
	100	56	3.4	3.9	4.5	5.2	5.8	6.8	7.8	9.1	10.2
	150	83	5.3	6.1	7.0	8.2	9.0	10.6	12.2	14.2	15.9
1.5	20	11	0.5	0.6	0.7	0.8	0.8	1.0	1.1	1.3	1.4
	50	28	1.3	1.5	1.7	1.9	2.1	2.4	2.8	3.2	3.6
	100	56	2.8	3.1	3.5	4.0	4.4	5.1	5.8	6.7	7.4
	150	83	4.3	4.8	5.5	6.3	6.9	8.0	9.1	10.5	11.6
2.0	20	11	0.5	0.5	0.6	0.6	0.7	0.8	0.9	1.0	1.1
	50	28	1.1	1.3	1.4	1.6	1.8	2.0	2.3	2.6	2.9
	100	56	2.4	2.7	3.0	3.4	3.7	4.2	4.8	5.5	6.0
	150	83	3.7	4.2	4.7	5.3	5.8	6.6	7.5	8.5	9.4
2.5	20	11	0.4	0.5	0.5	0.6	0.6	0.7	0.8	0.9	1.0
	50	28	1.0	1.2	1.3	1.4	1.6	1.8	2.0	2.3	2.5
	100	56	2.2	2.4	2.7	3.0	3.3	3.7	4.2	4.7	5.2
	150	83	3.4	3.7	4.2	4.7	5.1	5.8	6.5	7.4	8.1
3.0	20	11	0.4	0.4	0.5	0.5	0.6	0.6	0.7	0.8	0.9
	50	28	1.0	1.1	1.2	1.3	1.4	1.6	1.8	2.0	2.2
	100	56	2.0	2.2	2.4	2.7	2.9	3.3	3.7	4.2	4.6
	150	83	3.1	3.4	3.8	4.3	4.6	5.2	5.8	6.6	7.1
4.0	20	11	0.3	0.4	0.4	0.5	0.5	0.5	0.6	0.7	0.7
	50	28	0.9	0.9	1.0	1.1	1.2	1.4	1.5	1.7	1.8
	100	56	1.8	2.0	2.1	2.4	2.5	2.9	3.2	3.5	3.8
	150	83	2.8	3.0	3.4	3.7	4.0	4.4	4.9	5.5	6.0

**Note:** Multiply the W/ft heat loss values by 3.28 for W/m.

**TABLE 1 CONTINUED PIPE HEAT LOSS (Q<sub>B</sub>) FOR OUTDOOR OR BURIED PIPE (W/FT) FOR 4 TO 20 INCHES**

Insulation thickness (in)	(ΔT)		Pipe diameter (IPS) in inches								
	°F	°C	4	6	8	10	12	14	16	18	20
0.5	20	11	3.8	5.3	6.8	8.4	9.9	10.8	12.2	13.7	15.2
	50	28	9.6	13.6	17.4	21.4	25.2	27.5	31.3	35.0	38.8
	100	56	20.0	28.4	36.3	44.6	52.5	57.4	65.2	73.0	80.8
	150	83	31.2	44.3	56.6	69.6	81.9	89.5	101.7	113.8	126.0
1.0	20	11	2.1	2.9	3.7	4.5	5.3	5.8	6.5	7.3	8.0
	50	28	5.4	7.5	9.4	11.5	13.5	14.7	16.6	18.6	20.5
	100	56	11.2	15.6	19.7	24.0	28.1	30.6	34.7	38.7	42.8
	150	83	17.5	24.3	30.7	37.4	43.8	47.8	54.1	60.4	66.7
1.5	20	11	1.5	2.1	2.6	3.2	3.7	4.0	4.5	5.0	5.5
	50	28	3.9	5.3	6.7	8.1	9.4	10.2	11.5	12.9	14.2
	100	56	8.1	11.1	13.9	16.8	19.6	21.3	24.0	26.8	29.5
	150	83	12.7	17.3	21.6	26.2	30.5	33.2	37.5	41.8	46.1
2.0	20	11	1.2	1.7	2.1	2.5	2.9	3.1	3.5	3.9	4.3
	50	28	3.1	4.2	5.2	6.3	7.3	7.9	8.9	9.9	10.9
	100	56	6.6	8.8	10.9	13.1	15.2	16.5	18.6	20.7	22.8
	150	83	10.2	13.8	17.0	20.5	23.8	25.8	29.0	32.3	35.5
2.5	20	11	1.1	1.4	1.7	2.1	2.4	2.6	2.9	3.2	3.5
	50	28	2.7	3.6	4.4	5.2	6.1	6.6	7.4	8.2	9.0
	100	56	5.6	7.4	9.1	10.9	12.6	13.7	15.3	17.0	18.7
	150	83	8.7	11.6	14.2	17.0	19.7	21.3	23.9	26.5	29.1
3.0	20	11	0.9	1.2	1.5	1.8	2.0	2.2	2.5	2.7	3.0
	50	28	2.4	3.1	3.8	4.5	5.2	5.6	6.3	7.0	7.6
	100	56	4.9	6.5	7.9	9.4	10.8	11.7	13.1	14.5	15.9
	150	83	7.7	10.1	12.4	14.7	16.9	18.3	20.5	22.6	24.8
4.0	20	11	0.8	1.0	1.2	1.4	1.6	1.7	1.9	2.1	2.3
	50	28	2.0	2.5	3.1	3.6	4.1	4.4	5.0	5.5	6.0
	100	56	4.1	5.3	6.4	7.5	8.6	9.3	10.3	11.4	12.4
	150	83	6.4	8.3	10.0	11.8	13.4	14.5	16.1	17.8	19.4

**Note:** Multiply the W/ft heat loss values by 3.28 for W/m.

**TABLE 2 INDOOR PIPE HEAT LOSS MULTIPLES**

Fiberglass thickness (in)	Indoor multiple
0.5	0.79
1	0.88
1.5	0.91
2	0.93
2.5	0.94
3	0.95
4	0.97

**TABLE 3 INSULATION HEAT LOSS MULTIPLES**

k factor at 50°F (10°C) (BTU/hr-°F-ft <sup>2</sup> /in)	Insulation multiple	Examples of preformed pipe insulation
0.1-0.2	0.6	Rigid cellular urethane (ASTM C591)
0.2-0.3	1	Glass fiber (ASTM C547) Foamed elastomer (ASTM C534)
0.3-0.4	1.4	Cellular glass (ASTM C552) Mineral fiber blanket (ASTM C553)



Pipe Freeze Protection and Flow Maintenance	
1.	Determine design conditions and pipe heat loss
2.	Select the heating cable
3.	Determine the heating cable length
4.	Determine the electrical parameters
5.	Select the connection kits and accessories
6.	Select the control system
7.	Complete the Bill of Materials

## Step 2 Select the heating cable

To select the appropriate XL-Trace heating cable for your application, you must determine your cable supply voltage, power output, and outer jacket. Once you have selected these, you will be able to determine the catalog number for your cable.

### HEATING CABLE CATALOG NUMBER

Before beginning, take a moment to understand the structure of the heating cable catalog numbers. You will refer to this numbering convention throughout the product selection process. Your goal is to determine the catalog number for the product that best suits your needs.

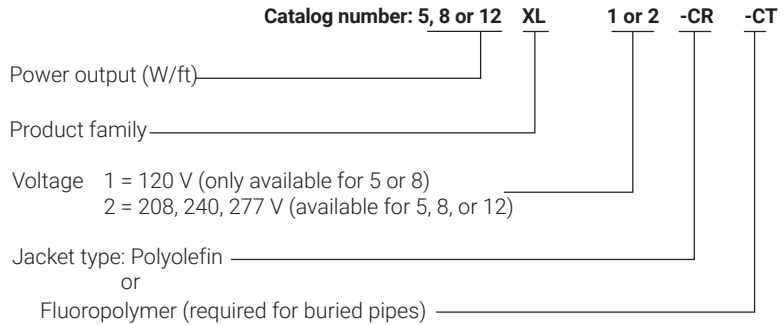

**Fig. 10 Heating cable catalog number**

Select the heating cable from Fig. 11 that provides the required power output to match the corrected heat loss for your application. Fig. 11 shows the power output for the heating cables on metal pipe at 120/208 volts. To correct the power output for other applied voltage or plastic pipes multiply the power output at the desired maintain temperature by the factors listed in Table 4 on page 18. If the pipe heat loss,  $Q_{CORRECTED}$ , is between the two heating cable power output curves, select the higher-rated heating cable.

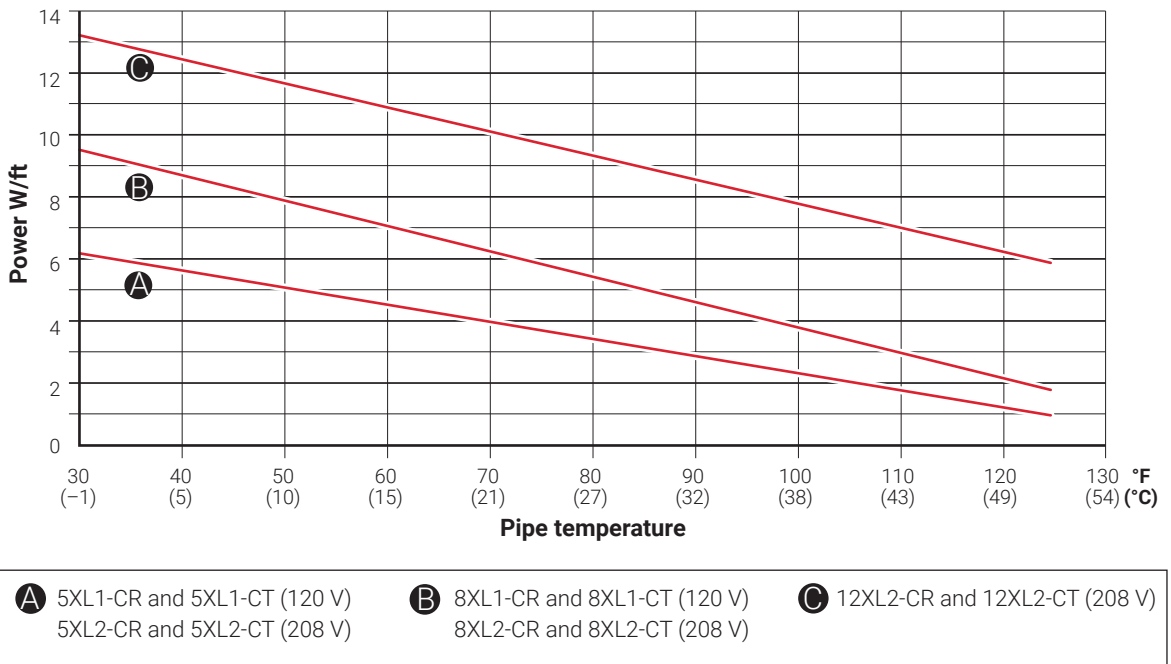

**Fig. 11 Heating cable power output on metal pipe**

**TABLE 4 POWER OUTPUT CORRECTION FACTORS**

Voltage correction factors	5XL1	8XL1	5XL2	8XL2	12XL2
120 V	1.00	1.00	–	–	–
208 V	–	–	1.00	1.00	1.00
240 V	–	–	1.12	1.12	1.14
277 V	–	–	1.29	1.27	1.30
<b>Plastic pipe correction factor</b> (With AT-180 Aluminum tape)	0.75	0.75	0.75	0.75	0.75

Confirm that the corrected power output of the heating cable selected is greater than the corrected pipe heat loss ( $Q_{CORRECTED}$ ). If  $Q_{CORRECTED}$  is greater than the power output of the highest-rated heating cable, you can:

- Use two or more heating cables run in parallel
- Use thicker insulation to reduce heat loss
- Use insulation material with a lower k factor to reduce heat loss

**Example: Fire Standpipe**

Pipe maintain temperature ( $T_M$ )	40°F (4°C) (from Step 1)
$Q_{CORRECTED}$	$Q_{CORRECTED} = 9.8 \text{ W/ft @ } T_M 40^\circ\text{F}$ (32.1 W/m @ $T_M 4^\circ\text{C}$ )
Supply voltage	208 V (from Step 1)
Pipe material	Metal (from Step 1)
Select heating cable	$Q_{CORRECTED} = 9.8 \text{ W/ft @ } T_M 40^\circ\text{F}$ (from Step 1) <b>12XL2 = 12.4 W/ft @ 40°F</b> (from Fig. 11)
Supply voltage correction factor	<b>1.00</b> (from Table 4)
Pipe material correction factor	<b>Metal = 1.00</b> (from Table 4)
Corrected heating cable power	<b>9.8 W/ft x 1.00 x 1.00 = 9.8 W/ft</b>
Selected heating cable	<b>12XL2</b>

**Example: Branch Line with Sprinkler**

Pipe maintain temperature ( $T_M$ )	40°F (4°C) (from Step 1)
$Q_{CORRECTED}$	$2.8 \text{ W/ft} \times 1.0 \times 0.97 = 2.2 \text{ W/ft @ } T_M 40^\circ\text{F}$ (7.3 W/m @ $T_M 4^\circ\text{C}$ )
Supply voltage	208 V (from Step 1)
Pipe material	Metal (from Step 1)
Select heating cable	$Q_{CORRECTED} = 2.2 \text{ W/ft @ } T_M 40^\circ\text{F}$ (from Step 1) <b>5XL2 = 5.6 W/ft @ 40°F</b> (from Fig. 11)
Supply voltage correction factor	<b>1.00</b> (from Table 4)
Pipe material correction factor	<b>Metal = 1.00</b>
Corrected heating cable power	<b>5.6 x 1.00 x 1.00 = 5.6 W/ft</b>
Selected heating cable	<b>5XL2</b>

## SELECT OUTER JACKET

Select the appropriate heating cable outer jacket for the application. Jacket options are:

- CR Compatible with most XL-Trace applications
- CT Required for buried piping; may be used in other XL-Trace applications for improved mechanical strength and chemical resistance.

### Example: Fire Standpipe

Location: Aboveground, outdoors  
 Selection: 12XL2-CR

### Example: Branch Line with Sprinkler

Location: Aboveground, indoors  
 Selection: 5XL2-CR

Pipe Freeze Protection and Flow Maintenance
1. Determine design conditions and pipe heat loss
2. Select the heating cable
3. Determine the heating cable length
4. Determine the electrical parameters
5. Select the connection kits and accessories
6. Select the control system
7. Complete the Bill of Materials

## Step 3 Determine the heating cable length

In Step 2 you selected the appropriate heating cable and the number of runs of heating cable required for the pipe. Multiply the length of the pipe by the number of heating cable runs for the heating cable length.

$$\text{Heating cable length} = \text{Pipe length} \times \text{No. heating cable runs}$$

Additional heating cable will be required for heat sinks and connection kits. Use Table 5 and Table 6 to determine the additional footage required for heat sinks (valves, flanges, and pipe supports). You will determine the additional heating cable for connection kits in Step 5. Round up fractional lengths to ensure heating cable lengths are sufficient.

$$\text{Total heating cable length required} = (\text{Pipe length} \times \text{No. heating cable runs}) + \text{Additional heating cable for heat sinks (valves, pipe supports, and flanges)}$$

**TABLE 5 ADDITIONAL HEATING CABLE FOR VALVES**

Pipe diameter (IPS) inches	Heating cable feet (meters)	
1/2	0.8	(0.24)
3/4	1.3	(0.4)
1	2.0	(0.6)
1-1/4	3.3	(1.1)
1-1/2	4.3	(1.3)
2	4.3	(1.3)
3	4.3	(1.3)
4	4.3	(1.3)
6	5.0	(1.5)
8	5.0	(1.5)
10	5.6	(1.7)
12	5.9	(1.9)
14	7.3	(2.2)
18	9.4	(2.9)
20	10.5	(3.2)

**TABLE 6 ADDITIONAL HEATING CABLE FOR PIPE SUPPORTS, FLANGES AND SPRINKLERS**

Support	Additional cable
Pipe hangers (insulated)	No additional heating cable
Pipe hangers (noninsulated) and U-bolt supports	Add 2x pipe diameter
Welded support shoes	Add 3x the length of the shoe
Flanges	Add 2x pipe diameter
Sprinklers	
Sprinkler without sprig	Add 4x pipe diameter
Sprinkler with sprig	Add 3x sprig length
Dry sprinkler for freezer application	Add 2x sprinkler length

**Note:** For applications where more than one heating cable is required per foot of pipe, this correction factor applies for each cable run.

**Example: Fire Standpipe**

Pipe length	50 ft (60 m) (from Step 1)
Pipe diameter	10-inch metal (from Step 1)
Number of heating cable runs	1 (from Step 2)
Valves	1 control valve 5.6 ft x 1 valve = 5.6 ft (1.7 m)
Pipe supports	5 pipe hangers with U-bolts 10-inch pipe diameter = $10/12 = 0.83$ [0.83 ft pipe diameter x 2] x 5 pipe supports = 8.3 ft (2.5 m)
Flanges	3 10-inch pipe diameter – $10/12 = 0.83$ ft [0.83 ft pipe diameter x 2] x 3 pipe supports = 5.0 ft (1.5 m)
Total heating cable for heat sinks	5.6 ft (1.7 m) + 8.3 ft (2.5 m) + 5.0 ft (1.5 m) = 18.9 ft (4.2 m) Rounded up to 19 ft (65 m)
Total heating cable length required	50 ft (15 m) x 1 run + 19 ft = <b>69 ft (21 m) of 12XL2-CR</b>

**Example: Branch Line with Sprinkler**

Pipe length	200 ft (61 m) (from Step 1)
Pipe diameter	1-inch metal (from Step 1)
Number of heating cable runs	1 (from Step 2)
Valves	2 gate valves [2.0 ft x 2 gate valves] x 1 run = 4.0 ft (1.2 m)
Pipe supports	10 noninsulated hangers 1-inch pipe diameter = $1/12 = 0.1$ ft [0.1 ft pipe diameter x 2] x 10 pipe supports] x 1 run = 2.0 ft (0.6 m)
Sprinklers	20 with 1 foot sprigs [3 x 1 ft sprig] x 20 = 60 ft (18.3 m)
Total heating cable for heat sinks	4.0 ft (1.2 m) + 2.0 ft (0.6 m) + 60 ft (18.3 m) = 66 ft (20.1 m)
Total heating cable length required	200 ft x 1 run + 66 ft = <b>266 ft (81 m) of 5XL2-CR</b>

Pipe Freeze Protection and Flow Maintenance
1. Determine design conditions and pipe heat loss
2. Select the heating cable
3. Determine the heating cable length
4. Determine the electrical parameters
5. Select the connection kits and accessories
6. Select the control system
7. Complete the Bill of Materials

#### Step 4 Determine the electrical parameters

To determine the electrical requirements for your application, you must determine the number of circuits and calculate the transformer load.

##### DETERMINE NUMBER OF CIRCUITS

To determine the number of circuits, you need to know:

- Total heating cable length
- Supply voltage
- Minimum start-up temperature

Use Table 7 to determine the maximum circuit length allowed. If the total heating cable length exceeds the maximum circuit length for the expected start-up temperature, more than one circuit will be required.

$$\text{Number of circuits} = \frac{\text{Heating cable length required}}{\text{Maximum heating cable circuit length}}$$

 **Important:** Select the smallest appropriate ground-fault circuit breaker size.

 **WARNING:** To minimize the danger of fire from sustained electrical arcing if the heating cable is damaged or improperly installed, and to comply with the requirements of nVent, agency certifications, and national electrical codes, ground-fault equipment protection must be used on each heating cable branch circuit. Arcing may not be stopped by conventional circuit protection.

**TABLE 7 MAXIMUM CIRCUIT LENGTH IN FEET**

Start-up temperature (°F)	CB size (A)	40°F Maintain										
		5XL1		5XL2			8XL2			12XL2		
		120 V	120 V	208 V	240 V	277 V	208 V	240 V	277 V	208 V	240 V	277 V
-20°F	15	101	76	174	178	183	131	138	146	111	114	117
	20	134	101	232	237	245	175	184	194	148	151	156
	30	201	151	349	356	367	262	276	291	223	227	234
	40	270	201	465	474	478	349	368	388	297	303	312
0°F	15	115	86	199	203	209	149	157	166	120	122	126
	20	153	115	265	271	279	199	209	221	160	163	168
	30	230	172	398	406	419	298	314	331	239	244	252
	40	270	210	470	490	530	370	390	420	319	326	336
20°F	15	134	100	232	237	244	173	182	192	126	129	133
	20	178	133	309	315	325	231	243	257	169	172	177
	30	270	200	464	473	488	346	365	385	253	258	266
	40	270	210	470	490	530	370	390	420	340	344	355
40°F	15	160	119	278	283	292	206	217	229	142	145	150
	20	214	159	370	378	390	275	290	306	190	194	200
	30	270	210	470	490	530	370	390	420	285	291	300
	40	270	210	470	490	530	370	390	420	340	360	380

**TABLE 8 MAXIMUM CIRCUIT LENGTH IN METERS**

Start-up temperature (°C)	CB size (A)	4°C Maintain										
		5XL1		5XL2			8XL2			12XL2		
		120 V	120 V	208 V	240 V	277 V	208 V	240 V	277 V	208 V	240 V	277 V
-29°C	15	31	23	53	54	56	40	42	44	34	35	36
	20	41	31	71	72	75	53	56	59	45	46	48
	30	61	46	106	108	112	80	84	89	68	69	71
	40	82	61	142	145	149	106	112	118	90	92	95
-18°C	15	35	26	61	62	64	45	48	51	36	37	38
	20	47	35	81	83	85	61	64	67	49	50	51
	30	70	52	121	124	128	91	96	101	73	74	77
	40	82	64	143	149	162	113	119	128	97	99	102
-7°C	15	41	31	71	72	74	53	56	59	39	39	41
	20	54	41	94	96	99	70	74	78	51	52	54
	30	82	61	141	144	149	106	111	117	77	79	81
	40	82	64	143	149	162	113	119	128	104	105	108
4°C	15	49	36	85	86	89	63	66	70	43	44	46
	20	65	48	113	115	119	84	88	93	58	59	61
	30	82	64	143	149	162	113	119	128	87	89	91
	40	82	64	143	149	162	113	119	128	104	110	116

**Example: Fire Standpipe**

Total heating cable length 69 ft (21 m) of 12XL2-CR (from Step 3)  
 Supply voltage 208 V (from Step 1)  
 Minimum start-up temperature -20°F (-29°C) (from Step 1)  
 Number of circuits  $69 \text{ ft} / (111 \text{ ft max } 15 \text{ A CB at } -20^\circ\text{F}) = 0.6 \text{ circuits}$

**Round up to 1 circuit**

**Example: Branch Line with Sprinkler**

Total heating cable length 266 ft (81 m) of 5XL2-CT (from Step 3)  
 Supply voltage 208 V (from Step 1)  
 Minimum start-up temperature 0°F (-18°C) (from Step 1)  
 Number of circuits  $266 \text{ ft} / (398 \text{ ft max } 30 \text{ A CB at } 0^\circ\text{F}) = 0.67 \text{ circuits}$

**Round up to 1 circuit**

**DETERMINE TRANSFORMER LOAD**

Transformers must be sized to handle the load of the heating cable. Use the following tables to calculate the total transformer load.

**TABLE 9 TRANSFORMER SIZING (AMPERES/FOOT)**

Minimum start-up temperature (°F)	5XL1	8XL1	5XL2			8XL2			12XL2		
	120	120	208	240	277	208	240	277	208	240	277
-20	0.119	0.159	0.069	0.067	0.065	0.092	0.087	0.082	0.108	0.106	0.102
0	0.105	0.139	0.060	0.059	0.057	0.080	0.076	0.072	0.100	0.098	0.095
20	0.090	0.120	0.052	0.051	0.049	0.069	0.066	0.062	0.095	0.093	0.090
40	0.075	0.101	0.043	0.042	0.041	0.058	0.055	0.052	0.084	0.083	0.080

**TABLE 10 TRANSFORMER SIZING (AMPERES/METER)**

Minimum start-up temperature (°C)	5XL1	8XL1	5XL2			8XL2			12XL2		
	120	120	208	240	277	208	240	277	208	240	277
-20	0.391	0.521	0.226	0.221	0.215	0.301	0.286	0.270	0.354	0.347	0.336
-18	0.343	0.457	0.198	0.194	0.188	0.264	0.251	0.238	0.329	0.322	0.312
-7	0.294	0.394	0.170	0.166	0.161	0.227	0.216	0.205	0.311	0.305	0.296
4	0.246	0.331	0.142	0.139	0.135	0.191	0.181	0.172	0.276	0.271	0.263

Use Table 9 or Table 10 to determine the applied voltage and the maximum A/ft (A/m) at the minimum start-up temperature to calculate the transformer load as follows:

$$\frac{\text{Max A/ft at minimum start-up temperature} \times \text{Heating cable length (ft)}}{1000 \times \text{Supply voltage}} = \text{Transformer load (kW)}$$

**Example: Fire Standpipe**

Total heating cable length 69 ft (21 m) of 12XL2-CR (from Step 3)  
 Supply voltage 208 V  
 Minimum start-up temperature -20°F (-29°C) (from Step 1)

$$\frac{\text{Max A/ft at } -20^{\circ}\text{F} \times \text{Total feet}}{1000 \times \text{Supply voltage}} = (0.108 \text{ A/ft} \times 69 \text{ ft} \times 208 \text{ V}) / 1000$$

**Transformer load (kW) = 1.68 kW**

**Example: Branch Line with Sprinkler**

Total heating cable length 266 ft (81 m) of 5XL2-CT (from Step 3)  
 Supply voltage 208 V  
 Minimum start-up temperature 0°F (-18°C) (from Step 1)

$$\frac{\text{Max A/ft at } 0^{\circ}\text{F} \times \text{Total feet}}{1000 \times \text{Supply voltage}} = (0.060 \text{ A/ft} \times 266 \text{ ft} \times 208 \text{ V}) / 1000$$

**Transformer load (kW) = 3.3 kW**

Pipe Freeze Protection and Flow Maintenance
1. Determine design conditions and pipe heat loss
2. Select the heating cable
3. Determine the heating cable length
4. Determine the electrical parameters
5. Select the connection kits and accessories
6. Select the control system
7. Complete the Bill of Materials

### Step 5 Select the connection kits and accessories

All XL-Trace systems require a power connection and end seal kit. Splice and tee kits are used as required. Use Table 11 on page 25 (for aboveground applications) and Table 13 on page 27 (for buried applications) to select the appropriate connection kits.

**Note:** Add extra cable on your Bill of Materials for power connections, tees, and end seals. See Table 11 on page 25, Table 13 on page 27, and Table 14 on page 28 for more information.

**WARNING:** Approvals and performance are based on the use of nVent-specified parts only. Do not substitute parts or use vinyl electrical tape.

### ABOVEGROUND PIPING

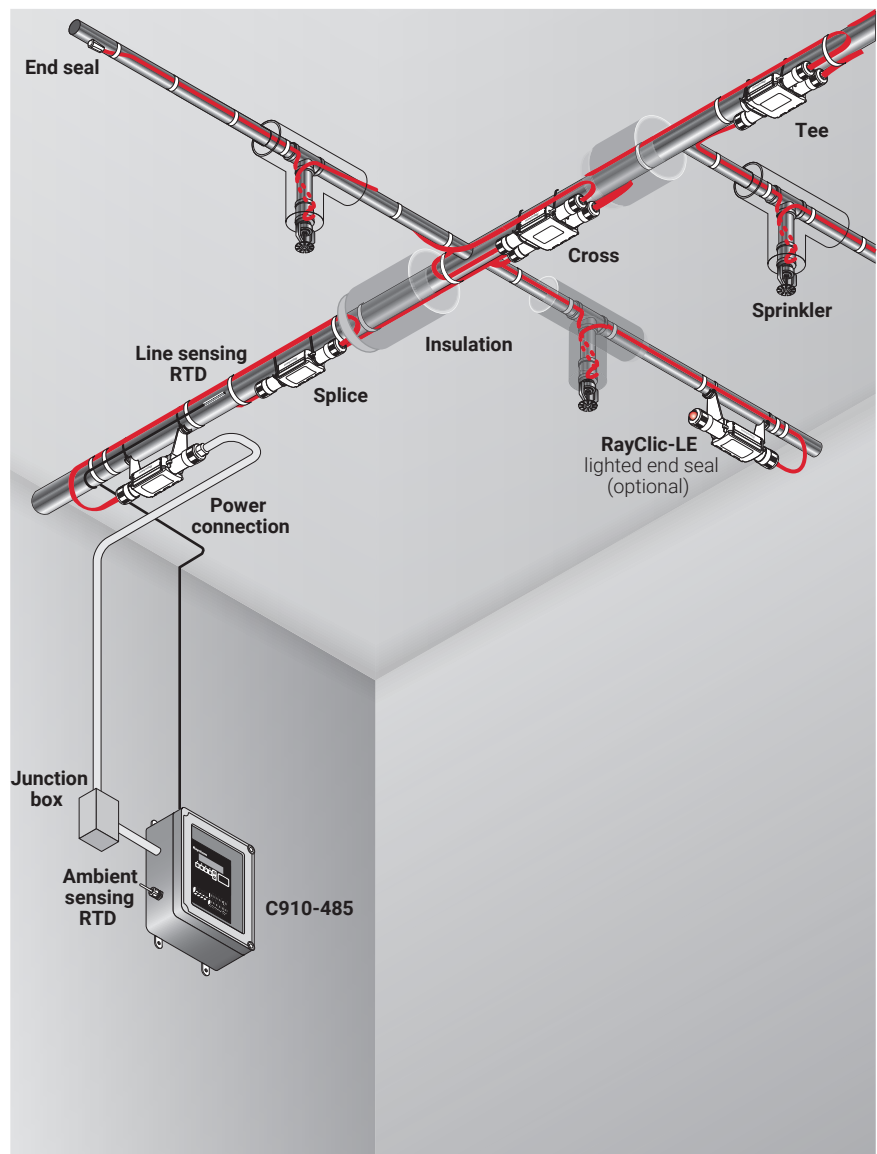
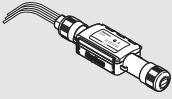
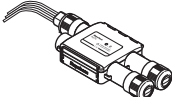
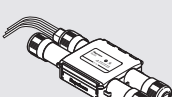
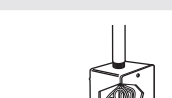
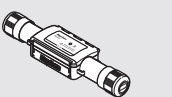
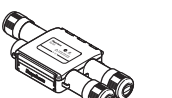
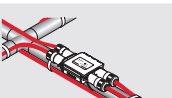





**Fig. 12 RayClic connection system**



Use the following table for general piping, standpipe and sprinkler. Develop a Bill of Materials from the connection kits listed in the following table



**TABLE 11 CONNECTION KITS AND ACCESSORIES FOR ABOVEGROUND PIPING**

	Catalog number	Description	Standard packaging	Usage	Heating cable allowance <sup>1</sup>
<b>Connection kits</b>					
	RayClic-PC	Power connection and end seal (RayClic-SB-04 pipe mounting bracket included)	1	1 per circuit	2 ft (0.6 m)
	RayClic-PS	Powered splice and end seal (RayClic-SB-04 pipe mounting bracket included)	1	1 per circuit	4 ft (1.2 m)
	RayClic-PT	Powered tee and end seal (RayClic-SB-04 pipe mounting bracket included)	1	1 per circuit	6 ft (1.8 m)
	FTC-P <sup>2</sup>	Power connection and end seal kit <b>Note:</b> FTC-P is required for circuits requiring 40 A circuit breakers.	1	1 per circuit	3 ft (0.9 m)
	RayClic-S	Splice used to join two sections of heating cable	1	As required	2 ft (0.6 m)
	RayClic-T	Tee kit with end seal; use as needed for pipe branches	1	As required	3 ft (0.9 m)
	RayClic-X	Cross connection to connect four heating cables	1	As required	8 ft (2.4 m)
	FTC-HST <sup>3</sup>	Low-profile splice/tee; use as needed for pipe branches	2	As required	3 ft (0.9 m)
	RayClic-LE	Lighted end seal (RayClic-SB-04 pipe mounting bracket included)	1	Alternate end seal	2 ft (0.6 m)
	RayClic-E	Replacement end seal	1	Additional end seal	0.3 ft (0.1 m)

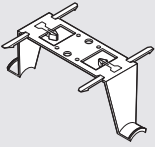
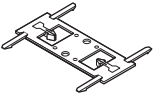
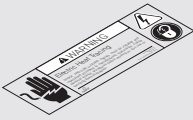
**TABLE 11 CONNECTION KITS AND ACCESSORIES FOR ABOVEGROUND PIPING**

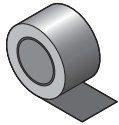
	Catalog number	Description	Standard packaging	Usage	Heating cable allowance <sup>1</sup>
<b>Accessories</b>					
	RayClic-SB-04	Pipe mounting bracket. Required for mounting the kits off the pipe for exposure temperatures greater than 150°F (65°C) and for grease and fuel line splices and tees.	1	As required	–
	RayClic-SB-02	Wall mounting bracket	1	As required	–
	ETL	“Electric Traced” label (use 1 label per 10 feet of pipe)	1	1 label per 10 feet (3 m) of pipe	–
	GT-66	Glass cloth adhesive tape for attaching heating cable to pipe at 40°F (4°C) or above.	66 ft (20 m)	See Table 12	–
	GS-54	Glass cloth adhesive tape for attaching heating cable to pipe above –40°F (–40°C).	54 ft (20 m)	See Table 12	–
	AT-180	Aluminum tape. Required for attaching heating cable to plastic pipe (use 1 foot of tape per foot of heating cable)	180 ft (55 m)	1 ft/ft (0.3 m/m) of heating cable	–

<sup>1</sup> Allow extra heating cable for ease of component installation.

<sup>2</sup> Junction box not included.

<sup>3</sup> One RayClic-E end seal is required for each FTC-HST used as a tee kit.

**TABLE 12 QUANTITY OF GLASS CLOTH ADHESIVE TAPE REQUIRED (ATTACH AT 1-FOOT INTERVALS)**

Pipe size (in)	<2	3	4	6	8	10
Feet of pipe per GT-66 roll	60 (18 m)	50 (15 m)	40 (12 m)	25 (8 m)	20 (6 m)	15 (5 m)
Feet of pipe per GS-54 roll	49 (15 m)	41 (13 m)	33 (10 m)	20 (6 m)	16 (5 m)	12 (4 m)

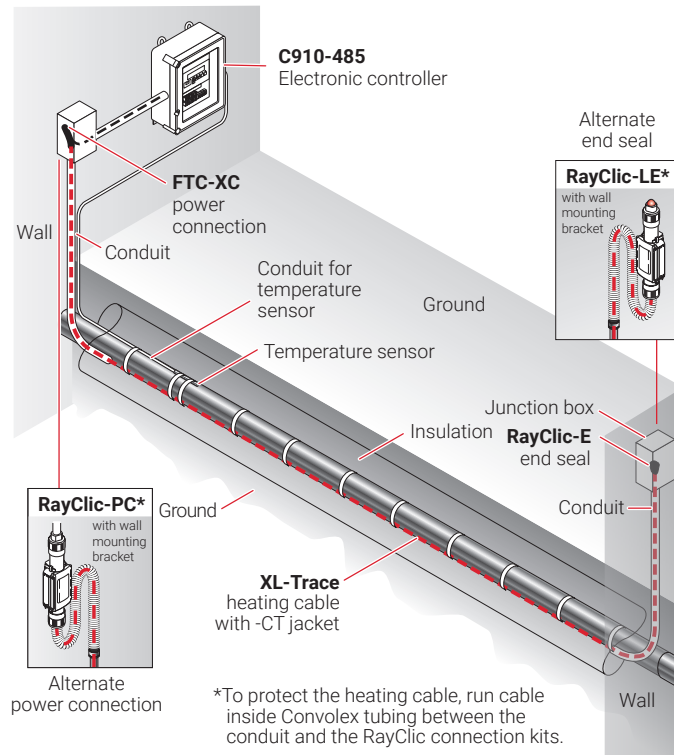

## BURIED PIPING



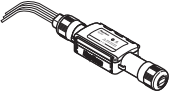
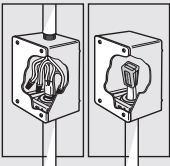
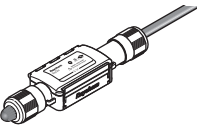
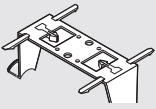
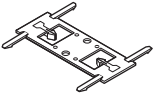
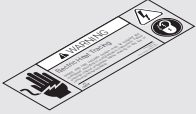

**Fig. 13 Typical buried supply piping system**

Use the following for buried water supply piping. Note that all connections must be aboveground and that no splices/tees are allowed. Develop a Bill of Materials from the connection kits in this table.

**TABLE 13 CONNECTION KITS AND ACCESSORIES FOR BURIED PIPING**

	Catalog number	Description	Standard packaging	Usage	Heating cable allowance <sup>1</sup>
	RayClic-PC	Power connection and end seal kit (RayClic-SB-04 pipe mounting bracket included)	1	1 per circuit	2 ft (0.6 m)
	FTC-XC <sup>2</sup>	The FTC-XC power connection and end seal kit is for use with XL-Trace heating cable that is run through conduit to a junction box. Materials for one power connection and end seal is included in the kit. <b>Note:</b> FTC-XC is required for circuits requiring 40 A circuit breakers.	1	1 per circuit	2 ft (0.6 m)
	RayClic-LE	Lighted end seal (RayClic-SB-04 pipe mounting bracket included)	1	Alternate end seal	2 ft (0.6 m)
	RayClic-E	Replacement end seal	1	Additional end seal	0.3 ft (0.1 m)

**TABLE 13 CONNECTION KITS AND ACCESSORIES FOR BURIED PIPING**

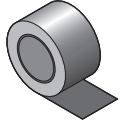
	Catalog number	Description	Standard packaging	Usage	Heating cable allowance <sup>1</sup>
<b>Accessories</b>					
	RayClic-SB-04	Pipe mounting bracket	1	As required	–
	RayClic-SB-02	Wall mounting bracket	1	As required	–
	ETL	“Electric Traced” label (use 1 label per 10 feet of pipe)	1	1 label per 10 feet (3 m) of pipe	–
	GT-66	Glass cloth adhesive tape for attaching heating cable to pipe at 40°F (4°C) or above	66 ft (20 m)	See Table 14	–
	GS-54	Glass cloth adhesive tape for attaching heating cable to pipe above –40°F (–40°C)	54 ft (20 m)	See Table 14	–
	AT-180	Aluminum tape. Required for attaching heating cable to plastic pipe (use 1 foot of tape per foot of heating cable)	180 ft (55 m)	1 ft/ft (0.3 m/m) of heating cable	–

<sup>1</sup> Allow extra heating cable for ease of component installation.

<sup>2</sup> Junction box not included.

**TABLE 14 QUANTITY OF GLASS CLOTH ADHESIVE TAPE REQUIRED (ATTACH AT 1-FOOT INTERVALS)**

Pipe size (in)	<2	3	4	6	8	10
Feet of pipe per GT-66 roll	60 (18 m)	50 (15 m)	40 (12 m)	25 (8 m)	20 (6 m)	15 (5 m)
Feet of pipe per GS-54 roll	49 (15 m)	41 (13 m)	33 (10 m)	20 (6 m)	16 (5 m)	12 (4 m)

Pipe Freeze Protection and Flow Maintenance
1. Determine design conditions and pipe heat loss
2. Select the heating cable
3. Determine the heating cable length
4. Determine the electrical parameters
5. Select the connection kits and accessories
6. Select the control system
7. Complete the Bill of Materials

## Step 6 Select the control system

Temperature control with heating cable circuit supervision is required by approval agencies, codes and nVent. To satisfy this requirement nVent offers a wide variety of monitoring and control options for fire suppression system.

C910-485 and ACS-30 are the only controllers approved for this application:

- Temperature controls save energy by ensuring that the system is energized only when necessary.
- Superior accuracy and reliability with RTD temperature sensors.
- Integrated 30 mA ground-fault protection for cost savings and circuit protection.
- Self-test features to ensure the heating cable circuit integrity even when the system is not in demand.
- Modbus® protocol communication over RS-485 system is supported using nVent RAYCHEM ProtoNode multi-protocol gateways.
- Dry contact alarm relay outputs for loss of power, low temperature, RTD failure, relay failure and ground-fault trip.



**Note:** NFPA 13 requires that heat tracing for fire suppression systems are supervised by controllers with alarm relays connected to the fire control panel.



Use the following table to identify the control system suitable for your application. Contact your nVent representative or call (800) 545-6258 for more information and other control options.

**TABLE 15 TEMPERATURE CONTROL OPTIONS**

Application	C910-485	ACS-30
Ambient sensing	x	x
Line sensing	x	x
Buried pipe	x	x
Proportional ambient control	x	x
Fire sprinklers	x	x
Sensor	RTD	RTD
Sensor length	See data sheet	See data sheet
Setpoint range	30°F to 200°F (-1°C to 92°C)	"
Enclosure	NEMA 4X	"
Differential	3°F (1.6°C)	"
Setpoint repeatability	3°F (1.6°C)	"
Enclosure limits	-40°F to 140°F (-40°C to 60°C)	"
Switch rating	30 A	30 A
Switch type	DPST	DPST
Electrical rating	100–277 V	100–277 V
Approvals	c-CSA-us	c-CSA-us
Ground-fault protection	20 mA to 100 mA	20 mA to 100 mA
BMS interface	Standard	Modbus <sup>1</sup>
Alarm outputs	x	x
AC relay dry contact relay	x	x

<sup>1</sup> ProtoNode multi-protocol gateways are available from nVent.

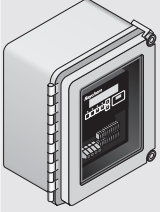
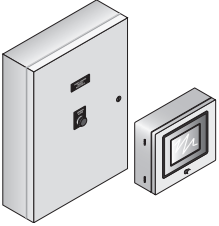
**TABLE 16 CONTROL SYSTEMS**

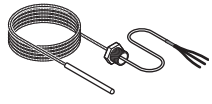
Catalog number	Description
<b>Electronic Controllers and Sensors</b>	
 <p>C910-485</p>	<p>The C910-485 is a compact, full-featured microprocessor-based single-point heat-trace controller. The C910-485 provides control and monitoring of electrical heat-tracing circuits for both freeze protection and temperature maintenance, and can be set to monitor and alarm for high and low temperature, and ground-fault level. The C910-485 controller is available with an electromechanical relay (EMR). Communications modules are available for remote control and configuration.</p> <p>The C910-485 includes RS-485 communications module for interfacing with Building Management Systems (BMS) and fire control panels.</p>
 <p>ACS-UIT2 ACS-PCM2-5</p>	<p>The ACS-30 Advanced Commercial Control System is a multipoint electronic control and monitoring system for heat-tracing used in commercial freeze protection and flow maintenance applications. The RAYCHEM ACS-30 system can control up to 260 circuits with multiple networked ACS-PCM2-5 panels, with a single ACS-UIT2 user interface terminal. The ACS-PCM2-5 panel can directly control up to 5 individual heat-tracing circuits using electromechanical relays rated at 30 A up to 277 V.</p>
 <p>ProtoNode-RER</p>	<p>The ProtoNode is an external, high performance multi-protocol gateway for customers needing protocol translation between Building Management Systems (BMS) and the ACS-30 or C910-485 controllers.</p> <p>The ProtoNode-RER is for BACnet® or Metasys® N2 systems.</p>
 <p>RTD-200 RTD3CS RTD10CS RTD50CS</p>	<p>Stainless steel jacketed three-wire RTD (Resistance Temperature Detector) used with C910-485 and ACS-30 controllers.</p> <p>RTD-200: 3-in (76 mm) temperature sensor with a 6-ft (1.8 m) lead wire and 1/2-in NPT bushing</p> <p>RTD3CS: temperature sensor with a 3-ft (0.9 m) flexible armor, 18-in (457 mm) lead wire and 1/2-in NPT bushing</p> <p>RTD10CS: temperature sensor with a 10-ft (3 m) flexible armor, 18-in (457 mm) lead wire and 1/2-inch NPT bushing</p> <p>RTD50CS: temperature sensor with a 50-ft (3 m) flexible armor, 18-in (457 mm) lead wire and 1/2-in NPT bushing</p>

Pipe Freeze Protection and Flow Maintenance
1. Determine design conditions and pipe heat loss
2. Select the heating cable
3. Determine the heating cable length
4. Determine the electrical parameters
5. Select the connection kits and accessories
6. Select the control system
7. Complete the Bill of Materials

**Step 7 Complete the Bill of Materials**

If you used the Design Worksheet to document all your design parameters, you should have all the details necessary complete your Bill of Materials.

## INSTALLATION AND MAINTENANCE

Follow the installation and maintenance procedures in the XL-Trace System Installation and Operation Manual (H58033) when installing XL-Trace on fire suppression systems with the following additional instructions.

When installing XL-Trace on sprinklers follow the methods shown below:

### Sprinkler head without sprig

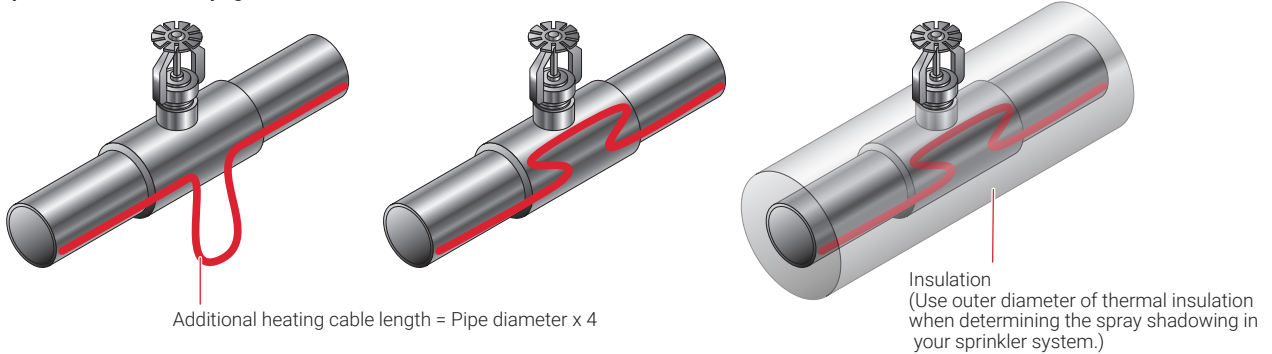

### Sprinkler head with sprig

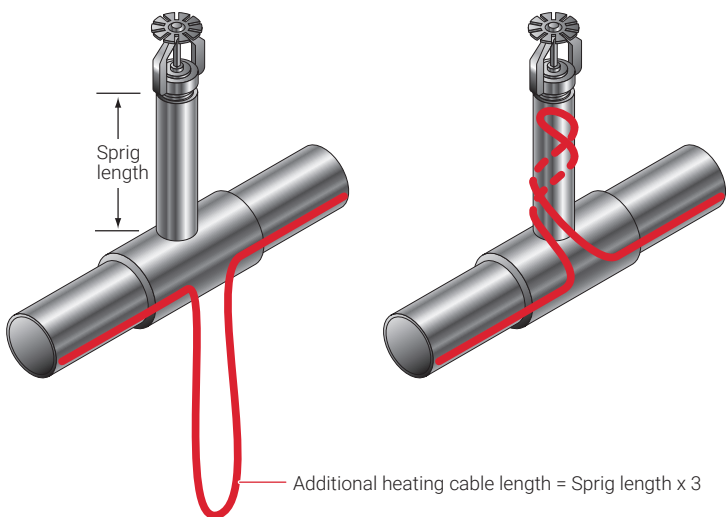

**Fig. 14 XL-Trace on sprinklers**

**Note:** The orientation and type of sprinkler head shown above is only for reference. The illustrations only depict the amount of heat tracing required and how to install it.

When installing XL-Trace on dry pendant sprinklers used in freezer applications follow the methods shown below:

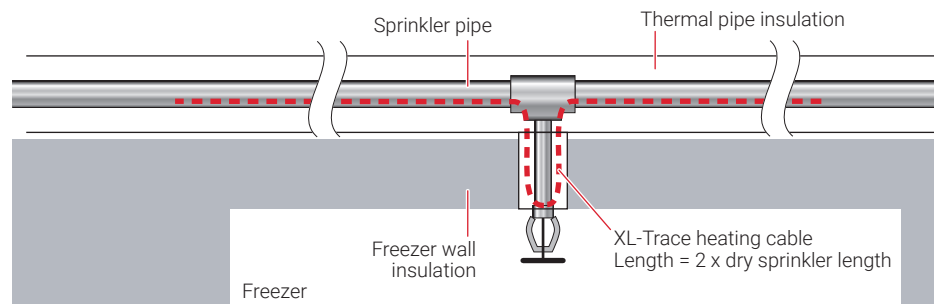

**Fig. 15 XL-Trace on extended pendant sprinklers**

**XL-TRACE SYSTEM FIRE SPRINKLER SYSTEM FREEZE PROTECTION DESIGN WORKSHEET**



TraceCalc Pro for Buildings is an online design tool available to help you create simple or complex heat-tracing designs for pipe freeze protection or flow maintenance applications. It is available at nVent.com.

**Step 1 Determine design conditions and pipe heat loss**

**Design conditions**

Fire sprinkler system	Location		Maintain temp. (T <sub>M</sub> )	Min. ambient temp. (T <sub>A</sub> )	Pipe diameter and material	Pipe length	Thermal insulation type and thickness	
<input type="checkbox"/> Supply piping	<input type="checkbox"/> Indoors	<input type="checkbox"/> Aboveground			<input type="checkbox"/> Metal		<input type="checkbox"/> Fiberglass	
<input type="checkbox"/> Standpipe	<input type="checkbox"/> Outdoors	<input type="checkbox"/> Buried	_____	_____	___ in <input type="checkbox"/> Plastic	___ ft (m)	<input type="checkbox"/> _____ in	
<input type="checkbox"/> Sprinkler piping	<input type="checkbox"/> Indoors	<input type="checkbox"/> Aboveground			<input type="checkbox"/> Metal		<input type="checkbox"/> Fiberglass	
	<input type="checkbox"/> Outdoors	<input type="checkbox"/> Buried	_____	_____	___ in <input type="checkbox"/> Plastic	___ ft (m)	<input type="checkbox"/> _____ in	
<input type="checkbox"/> Branchpipe	<input type="checkbox"/> Indoors	<input type="checkbox"/> Aboveground			<input type="checkbox"/> Metal		<input type="checkbox"/> Fiberglass	
	<input type="checkbox"/> Outdoors		_____	_____	___ in <input type="checkbox"/> Plastic	___ ft (m)	<input type="checkbox"/> _____ in	
<input type="checkbox"/> Branchpipe with sprinkler	<input type="checkbox"/> Indoors	<input type="checkbox"/> Aboveground			<input type="checkbox"/> Metal		<input type="checkbox"/> Fiberglass	
	<input type="checkbox"/> Outdoors		_____	_____	___ in <input type="checkbox"/> Plastic	___ ft (m)	<input type="checkbox"/> _____ in	
<b>Example:</b> <b>✓ Branch line with sprinkler</b>	<b>✓ Indoor</b>		<b>40°F</b>	<b>50°F</b>	<b>1 in</b>	<b>✓ Metal</b>	<b>200 ft</b>	<b>✓ Foam elastomer</b>
							<b>1/2 in</b>	

**Pipe heat loss**

**Calculate temperature differential ΔT**

Pipe maintain temperature (T<sub>M</sub>) \_\_\_\_\_  
°F (°C)

Ambient temperature (T<sub>A</sub>) \_\_\_\_\_  
°F (°C)

$$\frac{T_M}{T_M} - \frac{T_A}{T_A} \longrightarrow = \Delta T$$

**Example: Pipe Freeze Protection - Branch line with sprinkler**

Pipe maintain temperature (T<sub>M</sub>) 40 °F (from Step 1)  
°F

Ambient temperature (T<sub>A</sub>) 0 °F (from Step 1)  
°F

$$\frac{40 \text{ °F}}{T_M} - \frac{0 \text{ °F}}{T_A} \longrightarrow = 40 \text{ °F} \Delta T$$



**Determine the pipe heat loss:** See Table 1 for the base heat loss of the pipe ( $Q_B$ ). If the  $\Delta T$  for your system is not listed, interpolate between the two closest values.

$Q_{B-50}$ $\Delta T1$	_____
	W/ft (W/m)
$Q_{B-100}$ $\Delta T2$	_____
	W/ft (W/m)
$Q_B$	_____
	W/ft (W/m)
Pipe diameter	_____
	in
Insulation thickness	_____
	in
$\Delta T$	_____
	°F (°C)
$Q_{B-50}$	_____
	W/ft (W/m)
$Q_{B-100}$	_____
	W/ft (W/m)

**Example: Pipe Freeze Protection – Branch line with sprinkler**

Pipe diameter	_____
	1 in
Insulation thickness	_____
	1/2 in
$\Delta T$	_____
	40°F
$Q_{B-T1}$	_____
	1.4 W/ft
$Q_{B-T2}$	_____
	3.5 W/ft
$\Delta T$ interpolation	$\Delta T$ 40°F is 67% of the distance between $\Delta T$ 20°F and $\Delta T$ 50°F
$Q_{B-40}$	$Q_{B-50} + [0.67 \times (Q_{B-50} - Q_{B-20})] = 1.4 + [0.67 \times (3.5 - 1.4)] = 2.8$ W/ft
Pipe heat loss ( $Q_B$ )	<b>2.8 W/ft @ <math>T_M</math> 40°F (9.2 W/m @ <math>T_M</math> 4°C)</b>

### Compensate for insulation type and pipe location

See Table 1 for the pipe heat loss ( $Q_B$ ). If the  $\Delta T$  for your system is not listed, interpolate between the two closest values.

See Table 3 for insulation multiple

See Table 2 for indoor multiple

Location \_\_\_\_\_

Insulation thickness and type \_\_\_\_\_

$Q_B$  \_\_\_\_\_  
W/ft (W/m)

Insulation multiple \_\_\_\_\_

Indoor multiple (if applicable) \_\_\_\_\_

$$\frac{Q_B}{\text{_____}} \times \frac{\text{_____}}{\text{Insulation multiple}} \times \frac{\text{_____}}{\text{Indoor multiple (if applicable)}} = \frac{Q_{\text{CORRECTED}}}{\text{_____}}$$

#### Example: Pipe Freeze Protection – Branch line with sprinklers

Location	Indoors
Insulation thickness and type	1-1/2 in foamed elastomer
$Q_B$	2.8 W/ft @ $T_M$ 40°F (9.2 W/m @ $T_M$ 4°C)
Insulation multiple	1.00
Indoor multiple	0.79
$Q_{\text{CORRECTED}}$	2.8 W/ft x 1.0 x 0.79 = 2.2 W/ft @ $T_M$ 40°F (7.3/m @ $T_M$ 4°C)

## Step 2 Select the heating cable

**Power output data:** See Fig. 11

**Power output correction factors:** See Table 4

Pipe maintain temperature ( $T_M$ )	_____	(from Step 1)
Corrected heat loss ( $Q_{CORRECTED}$ )	_____	(from Step 1)
Supply voltage	_____	(from Step 1)
Pipe material (metal or plastic)	_____	(from Step 1)
XL-Trace application (water, fuel oil, or greasy waste)	_____	(from Step 1)
Pipe freeze protection: general water piping, sprinkler piping	_____	
Flow maintenance: greasy waste lines, fuel lines	_____	
Maximum system use temperature ( $T_{MAX}$ )	_____	(from Step 1)
Heating cable selected	_____	(from Step 1)
Power at $T_M$ (120/208 V)	_____	
Power output correction factor	_____	(from Step 1)
Plastic pipe correction factor	_____	
_____ x _____ = _____		
Power at rated V factor	Plastic pipe correction factor	Corrected power

Is the heating cable power output ( $P_{CORRECTED}$ )  $\geq$  the corrected heat loss?  Yes  No

If No, then design with additional runs of heating cable or thicker thermal insulation.

### Example: Pipe Freeze Protection – Branch line with sprinklers

Maintain temperature ( $T_M$ )	_____	40°F
Corrected heat loss ( $Q_{CORRECTED}$ )	_____	2.2 W/ft @ $T_M$ 40°F
Supply voltage	_____	208 V
Pipe material (metal or plastic*)	_____	metal

(\*AT-180 aluminum tape required for installing heating cable on plastic pipes)

$Q_B = 2.2 \text{ W/ft @ } T_M \text{ 40°F}$   
 Select curve C: 5XL2 = **5.6 W/ft @ 40°F**  
 Power output correction factor: 208 V = 1.00  
 Pipe material correction factor: Metal = 1.00  
 Corrected heating cable power: 5.6 @/ft x 1.00 x 1.00 = **5.6 W/ft**  
 Select: **5XL2**

### Select outer jacket

- CR
- CT (Required for buried applications)

### Example: Pipe Freeze Protection – Branch line with sprinklers

Location	Aboveground, indoors
Selection:	5XL2-CR

**Step 3 Determine the heating cable length**

**For additional heating cable allowance for valves:** See Table 5

**For additional heating cable allowance for pipe supports, flanges and sprinklers:** See Table 6.

**Additional heating cable for heat sinks**

$$\frac{\text{Type of valves}}{\text{How many}} \times \frac{\text{Additional heating cable}}{\text{Additional heating cable}} = \frac{\text{Total heating cable for valves}}{\text{Total heating cable for valves}}$$

$$\frac{\text{Type of pipe supports}}{\text{How many}} \times \frac{\text{Additional heating cable}}{\text{Additional heating cable}} = \frac{\text{Total heating cable for pipe supports}}{\text{Total heating cable for pipe supports}}$$

$$\frac{\text{Type of flanges}}{\text{How many}} \times \frac{\text{Additional heating cable}}{\text{Additional heating cable}} = \frac{\text{Total heating cable for flanges}}{\text{Total heating cable for flanges}}$$

$$\frac{\text{Type of sprinklers}}{\text{How many}} \times \frac{\text{Additional heating cable}}{\text{Additional heating cable}} = \frac{\text{Total heating cable for sprinklers}}{\text{Total heating cable for sprinklers}}$$

**Total heating cable for heat sinks:** \_\_\_\_\_

**Total heating cable length**

$$\left( \frac{\text{Pipe length}}{\text{Pipe length}} \times \frac{\text{Number of heating cable runs}}{\text{Number of heating cable runs}} \right) + \frac{\text{Additional cable for valves, pipe supports, flanges, and sprinklers}}{\text{Additional cable for valves, pipe supports, flanges, and sprinklers}} = \frac{\text{Total heating cable length required}}{\text{Total heating cable length required}}$$

**Example:**

**Additional heating cable for heat sinks**

$$\frac{\text{Gate valves}}{\text{How many}} \times \frac{\text{Additional heating cable}}{\text{Additional heating cable}} = \frac{\text{Total}}{\text{Total}}$$

$$\frac{\text{Noninsulated hangers}}{\text{How many}} \times \frac{\text{Additional heating cable}}{\text{Additional heating cable}} = \frac{\text{Total}}{\text{Total}}$$

$$\frac{\text{1 foot springs}}{\text{How many}} \times \frac{\text{Additional heating cable}}{\text{Additional heating cable}} = \frac{\text{Total}}{\text{Total}}$$

**Total:** \_\_\_\_\_

**Total heating cable length**

$$\left( \frac{\text{200 ft}}{\text{Pipe length}} \times \frac{\text{1}}{\text{Number of heating cable runs}} \right) + \frac{\text{66 ft}}{\text{Additional cable for valves, pipe supports, flanges, and sprinklers}} = \frac{\text{266 ft}}{\text{Total heating cable length required}}$$

## Step 4 Determine the electrical parameters

### Determine maximum circuit length and number of circuits

See Table 7 and Table 8.

Total heating cable length required \_\_\_\_\_

Supply voltage:  120 V  208 V  
 240 V  277 V

Circuit breaker size:  15 A  20 A  
 30 A  40 A

Minimum start-up temperature \_\_\_\_\_

Maximum circuit length \_\_\_\_\_

\_\_\_\_\_ / \_\_\_\_\_ = \_\_\_\_\_  
Total heating cable length required      Maximum heating cable circuit length      **Number of circuits**

#### Example:

Total heating cable length required 266 ft of 5XL2-CT

Supply voltage:  120 V  208 V  
 240 V  277 V

Circuit breaker size:  15 A  20 A  
 30 A  40 A

Minimum start-up temperature 0°F

Number of circuits 0.67 ft

266 ft / 398 ft = 0.67 circuits, round up to 2  
Total heating cable length required      Maximum heating cable circuit length      **Number of circuits**

### Determine transformer load

See Table 9 and Table 10.

\_\_\_\_\_ x \_\_\_\_\_ x \_\_\_\_\_ / 1000 = \_\_\_\_\_  
Max A/ft\* at minimum start-up temperature      Heating cable length      Supply voltage      **Transformer load (kW)**

#### Example:

0.06 A/ft x 266 ft x 208 V / 1000 = 3.3 kW  
Max A/ft\* at minimum start-up temperature      Heating cable length      Supply voltage      **Transformer load (kW)**

**Step 5 Select the connection kits and accessories**

See Table 11.

Connection kits – Aboveground	Description	Quantity	Heating cable allowance
<input type="checkbox"/> RayClic-PC	Power connection and end seal	_____	_____
<input type="checkbox"/> RayClic-PS	Power splice and end seal	_____	_____
<input type="checkbox"/> RayClic-PT	Powered tee and end seal	_____	_____
<input type="checkbox"/> FTC-P	Power connection and end seal	_____	_____
<input type="checkbox"/> RayClic-S	Splice	_____	_____
<input type="checkbox"/> RayClic-T	Tee kit with end seal	_____	_____
<input type="checkbox"/> RayClic-X	Cross connection	_____	_____
<input type="checkbox"/> FTC-HST	Low-profile splice/tee	_____	_____
<input type="checkbox"/> RayClic-LE	Lighted end seal	_____	_____
<input type="checkbox"/> RayClic-E	Extra end seal	_____	_____

Connection kits – Buried	Description	Quantity	Heating cable allowance
<input type="checkbox"/> RayClic-PC	Power connection and end seal	_____	_____
<input type="checkbox"/> FTC-XC	Power splice and end seal	_____	_____
<input type="checkbox"/> RayClic-LE	Lighted end seal	_____	_____
<input type="checkbox"/> RayClic-E	Extra end seal	_____	_____

Accessories – Aboveground and buried	Description	Quantity
<input type="checkbox"/> RayClic-SB-04	Pipe mounting bracket	_____
<input type="checkbox"/> RayClic-SB-02	Wall mounting bracket	_____
<input type="checkbox"/> ETL	“Electric-Traced” label	_____
<input type="checkbox"/> GT-66	Glass cloth adhesive tape	_____
<input type="checkbox"/> GS-54	Glass cloth adhesive tape	_____
<input type="checkbox"/> AT-180	Aluminum tape (for plastic pipes)	_____

**Total heating cable allowance for connection kits**

\_\_\_\_\_ + \_\_\_\_\_ =

Total heating cable length      Total heating cable allowance for connection kits

**Total heating cable length required**

---

**Step 6 Select the control system**

---

See Table 16.

---

<b>Thermostats, controllers and accessories</b>	<b>Description</b>	<b>Quantity</b>
<input type="checkbox"/> C910-485	Microprocessor-based single-point heat-tracing controller with RS-485 communication	_____
<input type="checkbox"/> ACS-UIT2	ACS-30 user interface terminal	_____
<input type="checkbox"/> ACS-PCM2-5	ACS-30 power control panel	_____
<input type="checkbox"/> ProtoNode-RER	Multi-protocol gateway	_____
<input type="checkbox"/> RTD3CS	Resistance temperature device	_____
<input type="checkbox"/> RTD10CS	Resistance temperature device	_____
<input type="checkbox"/> RTD-200	Resistance temperature device	_____
<input type="checkbox"/> RTD50CS	Resistance temperature device	_____

---

**Step 7 Complete the Bill of Materials**

---

Use the information recorded in this worksheet to complete the Bill of Materials.

**North America**

Tel +1.800.545.6258  
Fax +1.800.527.5703  
thermal.info@nVent.com



[nVent.com](https://www.nVent.com)

Our powerful portfolio of brands:

**CADDY ERICO HOFFMAN RAYCHEM SCHROFF TRACER**